

Dino DC400Ri

Surface Top Hammer Drills



Dino DC400Ri is a hydraulic, self-propelled, self-contained, crawler based surface drilling unit with full radio remote control.

Typical applications for DC400Ri are road construction, demolition works, secondary breaking, foundation drilling and trenching. Therefore DC400Ri is most often used by construction contractors, quarries and the municipal sector. Due to its versatility DC400Ri is perfect machine for drilling and blasting contractor.

Hole Diameter:	51 - 76 mm (2" - 3")
Rock Tools:	R32, T35, T38
Rock Drill:	14 kW
Engine Output:	105 kW (Tier4 final)
Flushing air:	3,5 m ³ /min, up to 8 bar
Production Capacity:	600 - 1200 m ³ /8h
Total Weight	abt. 10 000 kg

HYDRAULIC ROCK DRILL

Rock drill	RD414
Drill rods	R32, T35, T38
Operating pressure	110 - 220 bar
Percussion rate	56 - 78Hz
Percussion output power	14 kW
Maximum rotation torque	680 Nm
Shank lubrication	Air / oil mist
Flushing	Air
Weight	180 kg

FEED

Feed type	Chain feed CF400
Length of feed	6900 mm
Rock drill travel	3800 mm
Max. length of starter rod	4270 mm (14')
Hole depth with starter rod	3510 mm
Feed/pull out force	15 kN
Front centralizer	Pito 4
Feed extension travel	1300 mm
Feed swing	45/45°
Feed tilt	119°
Hose reel	Standard
Safety cage	Standard

ROD CHANGER

Rod handler type	RC400
Storage capacity	1 + 1
Steel length	14' + 12' + 10'
Max. hole depth	10 m +

BOOM

Boom type	DB410, articulated
Boom reach	5,2 m
Boom swing	+/- 45°
Drilling coverage on flat	18 m2
Collaring height	+1,65 m / -4,15 m
Horizontal holes	forward only

CARRIER

Type	Track mounted
Track type	FL 4
Grouser plate width	250 mm
Ground contact length	2450 mm
Ground pressure	0,8 kg/cm2
Ground clearance	400 mm
Oscillation angles	+/- 10°
Tramming force	100 kN
Max. tramming speed	3,2 km/h

POWERPACK

Engine type	Volvo Penta TAD570VE (Tier4 final)
Number of cylinders	4
Engine output	105 kW
Transmission type	Gearbox
Hydraulic pumps	2 variable displacement piston pumps
Screw compressor type	Enduro 12
Air flushing capacity	3,5 m ³ /min
Flushing air pressure	4 - 8 bar
Air filters	2 pcs
Fuel tank	210 l
DEF tank	AdBlue, 25 l
Fuel saving system	Standard

DUST COLLECTOR

Dust collector type	DC400H
Capacity/vacuum	16 m ³ /min at 855 mm vacuum H ₂ O
Filter elements/material	9 pcs/fiber
Total filter surface	7,2 m ²
Hydraulic motor output	9 kW
Primary cyclone	na
Movable suction head	Standard

CONTROL SYSTEM

System architecture	PLC controlled
User interface	Radio remote and screen
Percussion control	Feed – percussion follow up
Antijamming system	PLC controlled torque control
Voltage	24 VDC

HYDRAULIC SYSTEM

Drilling and tramming	Electric load sensing
Boom and Rod handling	Electric pressure control
Dust collector and coolers	Open loop with proportional pressure control
Filtration rate	10 micron abs.
Cooling capacity	up to +50°C ambient
Shank lubrication device	SLU 14-1
Hydraulic oil tank	235 l

STANDARD COMPONENTS

Rock drill RD414
Feed CF400
Rod handler; One rod add
Boom DB410; articulated
Carrier, track mounted
Power pack; diesel engine, hydraulic pumps and on-board compressor
Dust collector; DC400
Control system; radio remote control
Hydraulic system, electric load sensing
Gauge Set; For rock drill accumulators
Manuals; 1 x paper copy
Manuals; 1 x CD-ROM (Toolman)

Standard features:

Hose reel
Real time rock drill position
Stainless steel strips for feed
Safety cage for feed (After 12/2014)
Pressure filter for percussion line
Torque control
Led Lights 6 pcs
Oil heating circulation
Flushing control automatics
Shutdown of suction for waterholes

SELECTION OF OPTIONS

1.	Spirit level angle indicator
2.	TIM 5200 for vertical holes
3.	TIM 5300 for vertical holes and depth measuring
4.	TIM 6300 inclined holes, depth measuring and GPS aiming
5.	TIM 6500 inclined holes, depth measuring, laser level and GP
6.	Kit for alternative steels, each
7.	SLU based thread greasing
8.	Central lubrication system Sandvik
9.	Electric fuel filling pump
10.	Hydraulic winch

THE JAWS FOR DRILL STEELS

Drill steel type	Drill steel diameter	Recommended hole diameter
R32	R32 / 32 mm	51 – 76 mm
T35	T35 / 39 mm	54 – 76 mm
T38	T38 / 39 mm	64 – 76 mm

11.	Fuel powered heater for engine, SLU and water tank
12.	Flap feeder for dust collector
13.	Grinder Sandvik RG400
14.	Spare radio remote transmitter
15.	First service kit for DC400
16.	Special tools for RD414, field kit
17.	SanRemo - select level from extra item

COVERAGE AREA

Vertical drilling

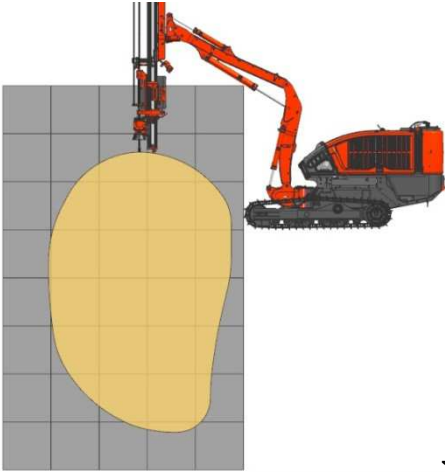

Vertical drilling

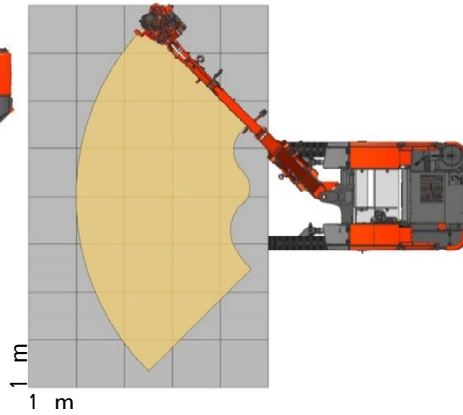

Horizontal drilling, forwards

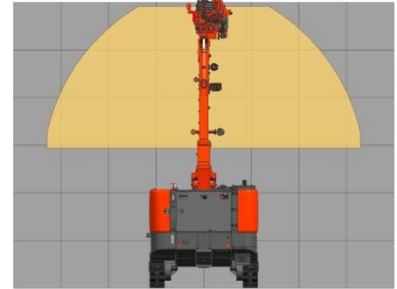

TRAMMING AND TRANSPORT DIMENSIONS

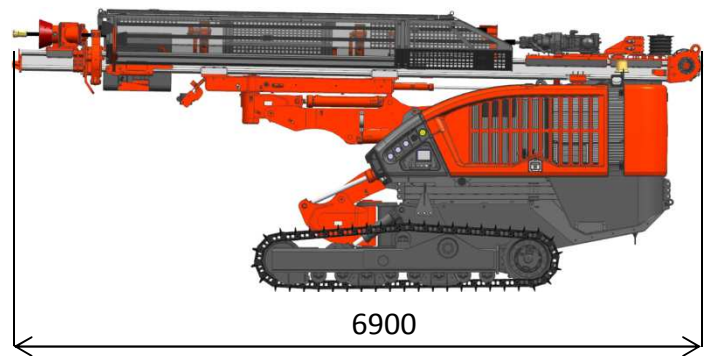
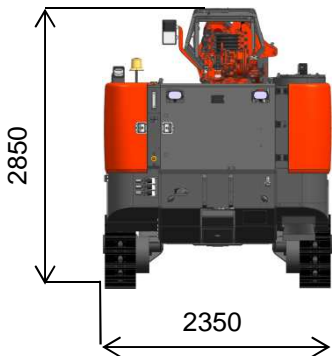

Weight (without options)	10 000 kg
Width	2350 mm
Height	2850 mm
Total length	6900 mm

Sandvik Mining and Construction reserves the right to change this specification without further notice.

Sandvik Mining and Construction Oy
 P.O.Box 100, FIN-33311 Tampere, Finland
 Tel. +358 205 44 121, Telefax +358 205 44 4771
www.sandvik.com

